

# A new high output impedance wideband AC current source with high current swing authority for electrical impedance tomography applications

Mehran Zanganeh

*Department of Electrical Engineering, University of Guilan, Rasht, Iran.  
Email Address: Zanganeh@msc.guilan.ac.ir*

*Received: 11 Aug. 2013, Revised: 17 Aug. 2013; Accepted: 20 Aug. 2013  
Published online: 1 Sep. 2013*

---

**Abstract:** The Electrical impedance tomography (EIT) is a relatively new technical imaging method for industrial applications, medical imaging and relative researches. The most important part of this system is an AC current source. Its characteristics have efficient effects on the performance of EIT systems. The AC current source must have constant current amplitude over the load and frequency ranges in related applications. In this paper, we could by designing a new topology of current source circuit achieving a current source with higher output impedance in comparison with other current sources which are mostly used in EIT applications. In the new designed current source, the output impedance of old current source will be multiplied by limited gain of second op-amp. Also in new topology, the output voltage and current swing are doubled in comparison with modified Howland current source; because, the load impedance seen from the output leg of second op-amp is decreased.

**Keywords:** AC current source, electrical impedance tomography (EIT), limited Gain of op-amp, new topology of current source, output current and voltage swing.

---

## I. INTRODUCTION

Electrical impedance tomography, EIT, (also called applied potential tomography) is a novel imaging technique with applications in medicine and process control [1]. Compared with techniques like computerised x-ray tomography and positron emission tomography (PET), EIT is about a thousand times cheaper, a thousand times smaller and requires no ionising radiation [2-4]. Further, EIT can in principle produce thousands of images per second [1,4]. Its major limitations are its low spatial resolution, and - in the medical field - large variability of images between subjects.

In the medical field, the most studied applications for EIT are measurement of gastric emptying and lung function. In the industrial field typical applications are imaging the distribution of oil and water in a pipeline and imaging the flow of substances in a mixing vessel. To measure resistivity, a current must be flow in the tissue and the resulting voltages be measured. This applied current will be referred to as the excitation current. In practice almost all EIT systems use an AC current sources, and measure voltage differences between adjacent pairs of electrodes [8]. To obtain an image with good spatial resolution, a number of such measurements are required. This can be achieved by applying different current distributions to the body, and

repeating the voltage measurements. From the set of measurements, an image reconstruction technique generates the tomographic image [1,4].

The most important part of EIT systems is the AC current source. For achieved high resolution images [2], we need to generate stable and constant magnitude AC current among the wide range of load and frequency domain [1,6] suitable for this applications. The current is applied to subject by electrodes connected to tissue of body and measuring the voltages between different arrays of electrodes. Usually the current magnitude is up to  $500\mu\text{A}$  and the frequency range is between 100Hz up to 1MHz [2], [7], [8] and load resistance is between  $200\Omega$  to  $2\text{k}\Omega$  in medicine applications [2].

A schematic of medical EIT system with electrode array attached to the patient's body is shown in Fig.1.[5]

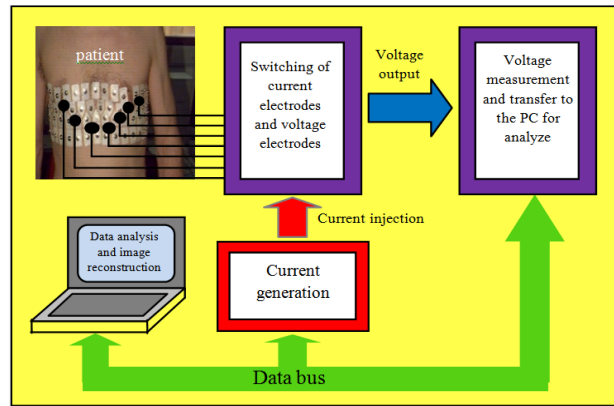

**Figure 1.** A schematic of medical EIT with electrode array attached to the patient's body.[5]

## II. THE CURRENT SOURCE

According to our previous paper [5], we obvious that for achieving high output impedance in high frequencies from the modified Howland current source, which is shown in Fig.2, and by using output impedance equation expressed by (1), the limited gain and gain-bandwidth of op-amp which is used in its structure must be high.

$$|Z_o| = \frac{3(2+a)}{8} \text{K}\Omega \approx \frac{3|a|}{8} \text{k}\Omega \quad (1)$$

or instance in order to have output impedance equal to  $1\text{M}\Omega$  in 1MHz, the gain-bandwidth of op-amp, according to (1), must be greater than 2.6GHz. It is very difficult to design of op-amp with  $\text{GBW}=2.6\text{GHz}$ . Therefore, we by designing a new topology of current source circuit, could achieving to new AC current source which prepares higher output impedance in compared with other AC current sources; also in new design, we can obtain higher output current swing in compared with other current sources.

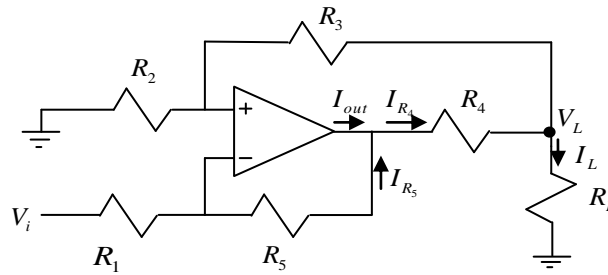

Figure 2. The modified Howland current source.[8]

### III. THE NEW TOPOLOGY OF AC CURRENT SOURCE

The circuit diagram of new topology of AC current source designed is shown in Fig.3.

As shown in Fig.3, the current source consist of two sections, first section prepare current and injecting current in the next section; the section2 cause increasing output impedance of current source totally.

We use the modified Howland current source in first portion; because it having high output impedance compared with the other current sources [6].

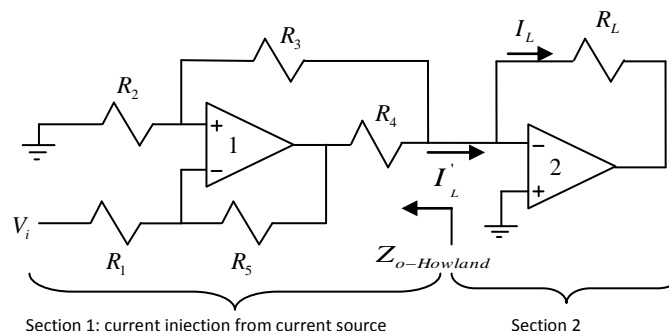

Figure 3. The new topology of current source designed.

Assuming the op-amps is ideal. In this case, the input legs of op-amp2 have same potentials; because the positive input leg of second op-amp is connected to ground of circuit; therefore, we can express that the negative input leg of second op-amp is connected to virtual ground. So, we can express that:

$$V_{in-opamp2}^+ = V_{in-opamp2}^- = 0 \quad (volt)$$

Thus, we can observe that the load resistance seen from modified Howland current source is equal to zero. Therefore we can express that the any change of load resistance (RL) will not have any effect on the output current of modified Howland current source. In this case, the output current is independent from the load resistance and we will have ideal AC current source from circuit shown in Fig.3.

### A. The Output Current

By assuming the ideal op-amps, the currents flow from the input legs of second op-amp will be zero, its mean that  $I_{in-opamp2}^+ = I_{in-opamp2}^- = 0$ . So, we can express that:

$$I_L = I_L' \quad (2)$$

According to our previous paper [5], in order for the circuit shown in Fig. 2 to acts as a current source, it is necessary to meet the criterion expressed by Eq. 3.

$$R_2 R_5 = R_1 (R_3 + R_4) \quad (3)$$

Therefore, the output current of circuit shown in Fig.2 and Fig.3 can be calculated from:

$$I_L = I_L' = -\frac{V_i}{R_4} \quad (4)$$

### B. The Output Impedance

By using op-amps in real case (limited gain, limited gain-bandwidth,...) The output impedance of new designed AC current source which is shown in Fig.3 is expressed by (5).

$$|Z_O| = Z_{O-Howland} \times (1 + a_{opamp2}) \quad (5)$$

As expressed in (5), we can see that the output impedance of modified howland current source is multiplied by:  $(1 + a_{opamp2})$ .

As expressed in section (II), for achieving high output impedance from modified Howland current source, the gain and also the gain-bandwidth of op-amp must be very high. Also, we know that, to achieving the op-amp with high gain-bandwidth, the power consumption of op-amp must be high, therefore, the maximum gain-bandwidth and also the maximum output impedance of howland current source is limited.

We by using new topology of current source could achieve high output impedance; while, its op-amps will not to have very high GBW in comparison with modified Howland current source op-amp.

For instance, to have output impedance greater than  $1M\Omega$  at  $1MHz$  of circuit in Fig.3, we need to have op-amp with GBW greater than  $51MHz$ , while in the same condition, the op-amp GBW of modified Howland current source must be greater than  $2.6GHz$ .

### C. Output Current Swing

By assuming ideal op-amp and using circuit shown in Fig.4, the output resistance seen from output leg of op-amp can be expressed as:

$$R_{O-opamp} = \frac{V_T}{I_T} = \frac{R_2 R_3 R_L (R_1 + R_5)}{(R_1 R_3 + R_1 R_L)(R_2 + R_3) + R_2 R_L (R_3 - R_1)} \quad (6)$$

Because the op-amp is ideal, so, positive and negative legs have same potential, therefore we can connect these by wire.

Under Eq.3 and an input voltage with magnitude of  $V_i=1V$ , to have a load current of  $I_L=1mA$  the resistors in Fig.2 must be selected as  $R_1= R_3= R_4= R_5=1k\Omega$ ,  $R_2=2k\Omega$ . Therefore, in this case, the output resistor seen from output leg of op-amp of circuit shown in Fig.2 is equal to  $666\Omega$ .

by using circuit shown in Fig.2, the output impedance seen from op-amp1 is equal to zero, because, in this case, the output load resistance of modified Howland current source is zero and connected to virtual ground ( $R_L = 0$ ); therefore, the output current swing from op-amp1 is increased. But, in the real case, the op-amp is non-ideal and the gain of op-amp is limited. In this condition, the load seen from Howland current source can be calculated as:

$$Z'_L = \frac{R_L}{1 + a_{opamp2}} \tag{7}$$

For instance, based on the designed op-amp in 0.18 $\mu$ m standard CMOS technology, which is shown in Fig.5, the GBW is equal to 107; therefore the gain of op-amp in 100 KHz is equal to 100. Now, if we suppose that the load resistor is equal to 1k $\Omega$ , therefore, according to (7), the load impedance seen from Howland current source will be equal to: 10 $\Omega$ .

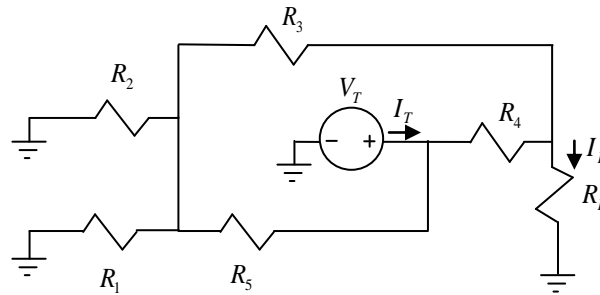

**Figure 4.** Circuit for calculating output resistance seen from output leg of op-amp1.

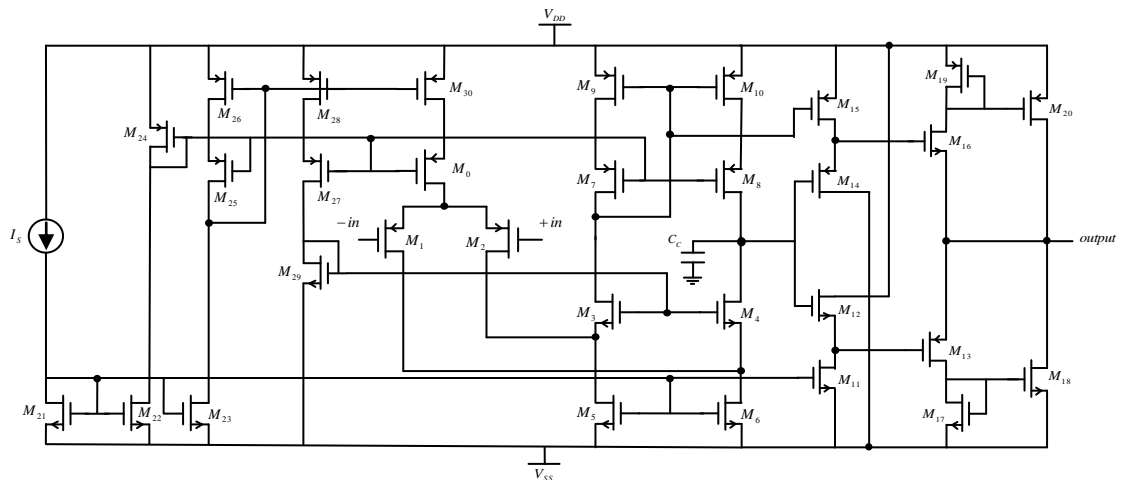

**Figure 5.** op-amp designed in 0.18 $\mu$ m standard Cmos technology.

According to designed op-amp which is shown in Fig.5, maximum voltage swing can be calculated as:

$$-V_{SS} + 2V_{on} + |V_{thPMOS}| < V_{out} < V_{DD} - 2V_{on} - V_{thNMOS} \tag{8}$$

We know that the maximum supply voltage in 0.18 $\mu\text{m}$  cmos technology is equal to  $\pm 1.65\text{v}$ . Now, If we bias the transistor  $M_{11}$ ,  $M_{15}$  in edge of ohmic and saturation region, therefore, the drain-source voltage of transistors will be nearly  $V_{DS-Sat}$ . Thus, according to these conditions the maximum output voltage swing of op-amps is equal to:

$$\left. \begin{array}{l} V_{th-NMOS} = |V_{th-PMOS}| = 0.65\text{v} \\ V_{on} = V_{DS-Sat} = 0.15\text{v} \end{array} \right\} \rightarrow -0.7 < V_{out-MAX} < 0.7\text{v}$$

Now, we can see that the maximum output current of op-amp used in modified Howland current source which is shown in Fig.2 is equal to:

$$\begin{aligned} -\frac{V_{out-MAX}}{R_{O-op-amp1}} < I_{out-MAX-opamp1} < \frac{V_{out-MAX}}{R_{O-op-amp1}} \\ -\frac{0.7\text{v}}{666\Omega} < I_{out-MAX-opamp1} < \frac{0.7\text{v}}{666\Omega} \\ -1.05\text{mA} < I_{out-MAX-opamp1} < 1.05\text{mA} \end{aligned} \quad (9)$$

While in the new topology, by replacing  $R_{O-op-amp1}=0$  the maximum output current swing of op-amp1 will be infinite; Of course, the maximum output current is restricted by the maximum output current which can be crossed from the push-pull stage of designed op-amp.

In the modified Howland current source which is shown in Fig.2, and according to above conditions, the maximum output current and delivered to load can be calculated as:

$$\left. \begin{array}{l} I_{R4} = I_{out} + I_{R5} \\ I_{R5-MAX} = \frac{-V_i}{R_1} = \frac{-1}{1\text{k}\Omega} = -1\text{mA} \end{array} \right\} \rightarrow I_{R4} = 0.05\text{mA}$$

$$\left. \begin{array}{l} V_{L-MAX} = V_{out-MAX} - R_4 I_{R4} = 0.7 - 1 \times 0.05 = 0.65\text{v} \\ I_{L-MAX} = I_{R4} - \frac{V_{L-MAX} - V_{in}^+}{R_3} \\ V_{in}^+ = \frac{R_2}{R_2 + R_3} V_L = \frac{2}{3} V \\ R_L = 1\text{k}\Omega \end{array} \right\} \rightarrow I_{L-MAX} = 383\mu\text{A}$$

Therefore, the maximum output current delivered to load of modified Howland current source, approximately is equal to 380 $\mu\text{A}$ .

While, in the same conditions, the maximum output current of new designed current source which is shown in Fig.3 can be calculated as:

$$\frac{-V_{SS} + 2V_{on} + |V_{th-PMOS}|}{R_L} < I_{L-MAX} < \frac{V_{DD} - 2V_{on} - V_{thNMOS}}{R_L} \quad (10)$$

In the same conditions of recently example, maximum output current of new designed current source will be equal to:

$$\left. \begin{aligned} V_{DD} = -V_{SS} = 1.65\text{v}, V_{on} = 0.15\text{v}, V_{th} = 0.65\text{v}, R_L = 1\text{K}\Omega \\ \frac{-V_{SS} + 2V_{on} + |V_{thPMOS}|}{R_L} < I_{L-MAX} < \frac{V_{DD} - 2V_{on} - V_{thNMOS}}{R_L} \end{aligned} \right\} \rightarrow -700\mu\text{A} < I_{L-MAX} < 700\mu\text{A}$$

Therefore, According to recently examples, we observe that, the maximum output current and delivered to load in the new current source is higher than the modified Howland current source (it is approximately doubled).

Thus, we can express that the new topology of current source which is shown in Fig.3 has higher output current swing in comparison with other ac current source which is mostly used.(for example, modified Howland current source).

#### IV. SIMULATION RESULTS

We using from the Cadence IC design tools software to designing and simulating circuits. The results of simulations are shown in current sections.

By using of designed op-amp in modified Howland current source which is shown in Fig.2, we can observe form Fig.6.a, the maximum output current and delivered to load is restricted to 350μA, while the load connected is equal to 1kΩ, in 100 KHz frequency and input sinusoidal voltage signal amplitude is equal to 1v. While, in the same conditions, we can observe that from Fig.6.b, the maximum output current of new designed current source is restricted to 800μA.

Therefore, we can express that, the new designed current source have higher output current swing in comparison with modified Howland current source.

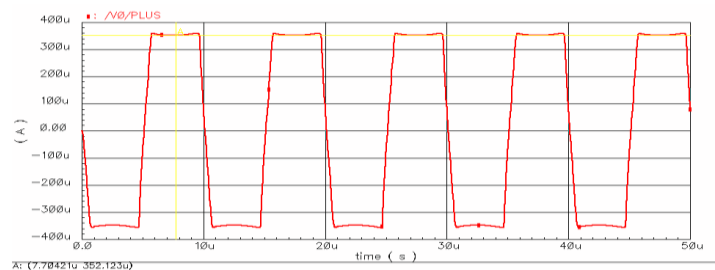

(a)

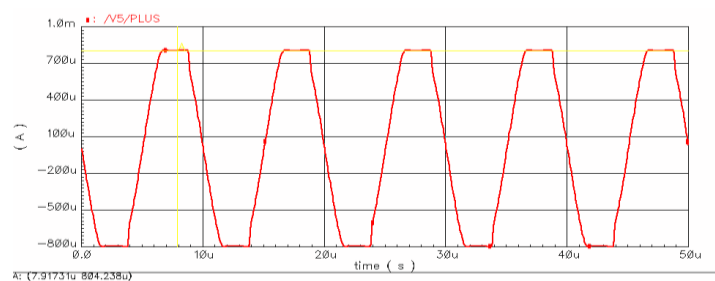

(b)

**Figure 6.** Output current in 100KHz frequency and RL=1kΩ for a) modified Howland current source. b) new designed current source.

With applying 750mv sinusoidal input voltage signal, 1kΩ load resistance connected to new designed current source and frequency of 100 KHz, 1 MHz, the output current wave crossed from the load is shown in figure.7.

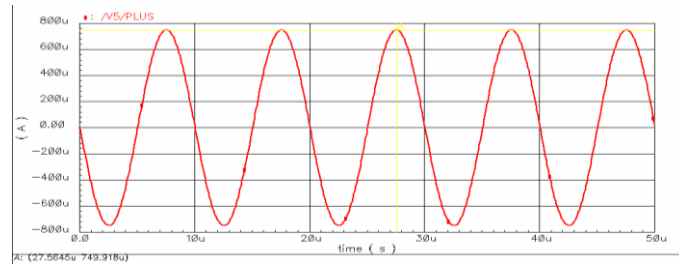

(a)

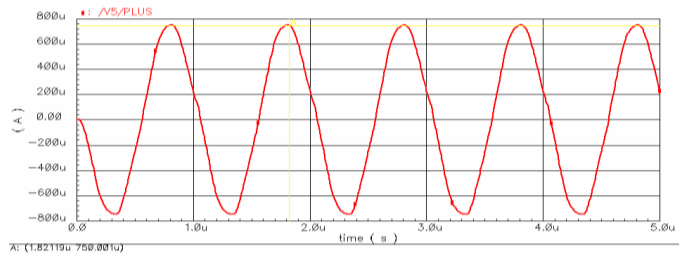

(b)

**Figure 7.** Output current of new designed current source while  $V_i=750\text{mv}$ ,  $R_L=1\text{K}\Omega$ . a) in 100KHz frequency, b) in 1MHz frequency

As shown in Fig.7.a and Fig.7.b, we can observe that, the output current amplitude is equal to 750mA; also we can observe that the output current is stable in low frequency (100KHz) and high frequency (1MHz).

By Ac analysis of output impedance for modified Howland current source and new designed current source in frequency ranges from 1Hz to 1MHz which is shown in Fig.8; we can express that, the output impedance of new designed current source is very higher in comparison with the modified Howland current source.

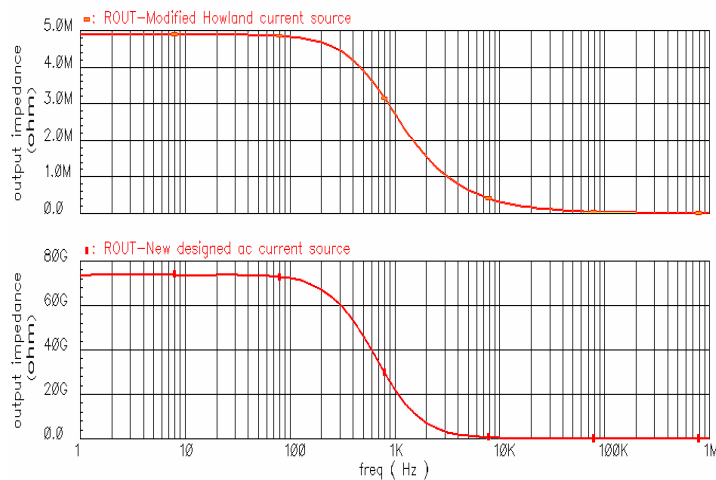

**Figure 8.** Output impedance of modified Howland current source and new designed ac current source. from 1Hz to 1MHz.



According to Fig.8 we can observe that the output impedance of two current source is enough high in low frequencies and we not have any problem in low frequencies, but, in high frequencies the output impedance of current sources is very low ( $3.3\text{k}\Omega$  at  $1\text{MHz}$  for modified Howland current source and  $33\text{k}\Omega$  for new designed current source); so, we have problem in high frequency. This problem can be solved by using new designed current source which have higher output impedance in comparison with modified Howland current source. If we design and use an op-amp with high enough GBW, so, we can achieve to high enough output impedance in high frequencies. For instance, if we want to have loads current with  $0.1\%$  tolerance in the frequency and load ranges [9], therefore, the output impedance of current source must be more than  $1\text{M}\Omega$ . So, in this condition, two op-amps, which are used in new designed current source, must be having the GBW more than  $51\text{MHz}$ . while, in the same condition, the op-amp used in the modified Howland current source, must be have GBW greater than  $2.6\text{GHz}$ .

## CONCLUSION

We by designing and simulating of new topology of AC current source could achieve an AC current source with high output impedance and high current swing capability in comparison with other current sources which are mostly used in EIT applications (for example: modified Howland current source). Also, we observed that in the new designed current source, we can use op-amps with very lower GBW in comparison with op-amp used in modified Howland current source; this is important and causing to design op-amp with lower power consumption and easier design of op-amp circuits.

## References

- [1] Li Y., Rao L., He R., Xu G., Wu Q., Yan W., Dong G. and Yang Q., A Novel Combination Method of Electrical Impedance Tomography Inverse Problem for Brain Imaging , *IEEE Transactions on Magnetics*, **41**(5), (2005), pp. 1848-1851.
- [2] H. Hong, M. Rahal, A. Demosthenous and R. H. Bayford, Floating Voltage-Controlled Current Sources for Electrical Impedance Tomography, In Proceedings of the 18th European Conference on Circuit Theory and Design, 2007. ECCTD 2007, (2007), pp. 208-211.
- [3] T. K. Bera and N. Jampana, A Multifrequency Constant Current Source Suitable for Electrical Impedance Tomography (EIT), *In Proceedings of International Conference on Systems in Medicine and Biology*, December (2010), pp. 278-283.
- [4] D. Zhao, High output-impedance current source for electrical impedance tomography, *In Proceedings of the 4th International Conference on Biomedical Engineering and Informatics (BMEI)*, *IEEE*, (2011), pp. 1106-1109.
- [5] A. Heidari, M. Zanganeh, M. Nahvi and S. Nihtianov, The Impact of Resistor Mismatches and Op-amp Limited GBW on the Output Impedance of the Howland Current Source for EIT Applications, *Annual Journal of Electronics, XXII international scientific conference, bulgaria, sozopol*, (2013).
- [6] C. W .Denyer, F.J.Lidgey WEE, Q.S.Zhu MIEEE and C.N.McLeod, high output impedance voltage controlled current source for bio-impedance instrumentation, 0-7803-1377-1/93 IEEE, (1993), pp. 1026-1027.
- [7] J. Frounchi, F. Dehkhoda and M. H. Zarifi, A Low-Distortion Wideband Integrated Current Source for Tomography Applications, *European Journal of Scientific Research*, **27**(1), © EuroJournals Publishing, Inc., (2009), pp. 56-65.
- [8] A. S. Ross, G. J. Saulnier, J. C. Newell and D. Isaacson, Current source design for electrical impedance tomography, *Physiol. Meas.* **24** (2), IOP Publishing, (2003), pp. 509–516.
- [9] R. Brag, J. Rose and Pere Riu, A wide-band AC-coupled current source for electrical impedance tomography , *Physiol. Meas.*, **15** (1994) A91-A99. Printed in the UK, (1994).